



# User Manual

SPI-B Series (5k-20k)  
String PV Grid-Connected Inverter



**Copyright © Kehua Hengsheng Co., Ltd. 2019. All rights reserved.**

No part of this document may be reproduced or transmitted in any form or by any means without prior written consent of Kehua Hengsheng Co., Ltd.

### **Trademarks and Permissions**



and other Kehua trademarks are trademarks of Kehua Hengsheng Co., Ltd.

All other trademarks and trade names mentioned in this document are the property of their respective holders.

### **Notice**

The purchased products, services and features are stipulated by the contract made between Kehua and the customer. All or part of the products, services and features described in this document may not be within the purchase scope or the usage scope. Unless otherwise specification in the contract, all statements, information, and recommendations in this document are provided "AS IS" without warranties, guarantees or representations of any kind, either express or implied.

The information in this document is subject to change without notice. Every effort has been made in the preparation of this document to ensure accuracy of the contents, but all statements, information, and recommendations in this document do not constitute a warranty of any kind, express or implied.

## **KEHUA HENGSHENG CO.,LTD.**

Address:	No.457,MalongRoad,TorchHigh-TechIndustrialZone,Xiamen,Fujian,China
Manufacturer:	ZHANGZHOU KEHUA TECHNOLOGYCO.,LTD.
Postal Code:	361000(XIAMEN), 363000(ZHANGZHOU)
Website:	www.kehua.com
E-mail:	service@kehua.com
Customer Service Telephone:	400-808-9986
Tel:	0592-5160516
Fax:	0592-5162166

# Foreword

## Summaries

Thank you for choosing Kehua's string PV Grid-Connected Inverter (hereinafter referred to as the "inverter").

This document gives a description of SPI-B series inverter, including the features, performance, appearance, structure, working principles, installation, operation and maintenance.etc.

Please save the manual after reading, in order to consult in the future.



### NOTE

The figures in this manual are just for reference, for details please see the actual product.





## Suitable Model



The manual is suitable for following models:

- SPI5K-B、SPI6K-B、SPI8K-B、SPI10K-B、SPI12K-B、SPI15K-B、SPI17K-B、SPI20K-B.

## Symbol Conventions

The manual quotes the safety symbols, these symbols used to prompt users to comply with safety matters during installation, operation and maintenance. Safety symbol meanings follows.

Symbol	Description
 <b>DANGER</b>	Alerts you to a high risk hazard that could, if not avoided, result in serious injury or death.
 <b>WARNING</b>	Alerts you to a medium or low risk hazard that could, if not avoided, result in moderate or minor injury.
 <b>CAUTION</b>	Alerts you to a potentially hazardous situation that could, if not avoided, result in equipment damage, data loss, performance deterioration, or unanticipated results.
	Anti-static prompting.

Symbol	Description
	Be care electric shock prompting.
 <b>TIP</b>	Provides a tip that may help you solve a problem or save time.
 <b>NOTE</b>	Provides additional information to emphasize or supplement important points in the main text.

Product standard: Q/XMHS 003

## Revision History

Changes between document versions are cumulative. The latest document version contains all the changes made in earlier version.

### Version 002 (2019-04-02)

1. Change the Figure2-7.
2. Making the SPI12K-B belong to the series of SPI15K-B、SPI17K-B、SPI20K-B.

### Version 001 (2019-01-29)

First release.

# Contents

<b>1 Safety Description .....</b>	<b>1</b>
1.1 Safety Announcements .....	1
1.1.1 Safety Instructions .....	1
1.1.2 Protection for PV Array .....	3
1.1.3 Anti-Static Protection .....	3
1.1.4 Grounding Requirements .....	3
1.1.5 Moisture-proof Protection .....	4
1.1.6 Safety Warning Label Setting .....	4
1.1.7 Electrical Connection .....	4
1.1.8 Measure with Electricity .....	5
1.2 Requirements for Operator .....	5
1.3 Environment Requirements .....	6
1.4 Device Label Illustration .....	6
<b>2 Overview .....</b>	<b>8</b>
2.1 Product Intro .....	8
2.1.1 Model Meaning .....	8
2.1.2 Product Features .....	8
2.2 Appearance and Structure .....	9
2.2.1 Operation Panel .....	9
2.2.2 External Terminal Illustration .....	10
2.3 Work Principle .....	12
2.4 Grid Form .....	12
<b>3 Installation Guide .....</b>	<b>14</b>
3.1 Installation Process .....	14

3.2 Installation Preparation .....	14
3.2.1 Tools.....	14
3.2.2 Installation Environment.....	15
3.2.3 Installation Space .....	16
3.2.4 Installation Way .....	17
3.3 Transportation and Unpacking .....	17
3.3.1 Transportation .....	17
3.3.2 Unpacking and Checking.....	17
3.4 Installation.....	19
3.5 Electrical Connection .....	23
3.5.1 Wire Requirement .....	23
3.5.2 External Grounding Connection .....	23
3.5.3 DC Input (PV) Connection .....	24
3.5.4 AC Output (AC OUTPUT) Connection.....	28
3.5.5 WIFI/GPRS Communication Connection.....	30
3.5.6 COM. Communication Connection(Options) .....	31
3.6 Check the Installation.....	34
<b>4 LCD Operation .....</b>	<b>35</b>
4.1 Display Interface .....	35
4.2 First Startup.....	36
4.3 Main Page .....	36
4.3.1 Running Information.....	37
4.3.2 Power Query .....	37
4.3.3 Record Query .....	38
4.3.4 System Setting .....	39
4.3.5 System Information.....	41
<b>5 Startup and Shutdown.....</b>	<b>42</b>
5.1 Startup .....	42
5.2 Shutdown .....	42

---

<b>6 Maintenance and Troubleshooting .....</b>	<b>43</b>
6.1 Maintenance .....	43
6.1.1 Inverter Maintenance .....	43
6.1.2 Fan Maintenance (SPI12K-BL, SPI15K-B, SPI17K-B, SPI20K-B).....	43
6.2 Troubleshooting.....	45
<b>7 Package, Transportation and Storage.....</b>	<b>48</b>
7.1 Package .....	48
7.2 Transportation .....	48
7.3 Storage .....	48
<b>A Technical Specifications .....</b>	<b>49</b>
<b>B Acronyms and Abbreviations .....</b>	<b>56</b>



# 1 Safety Description

This chapter introduces the safety announcements. Please read this user manual carefully prior to installing the inverter. It provides important information on safe and efficient installation.

## 1.1 Safety Announcements



### CAUTION

Before operation, please read the announcements and operation instructions in this part, which is to avoid accident.

The DANGER, WARNING, CAUTION in the manual, are not all the safety announcements that must be abided by, they are just the supplement of the safety announcements during operating.

---



### NOTE

Kehua Company does not undertake the responsibility caused by violating common safety operation requirements or the safety standard of design, manufacture and use.

### 1.1.1 Safety Instructions



### DANGER

It is prohibited touching any terminal or conductor that connected with grid circuit, or, it may cause deadly danger.

---

**DANGER**

There is no operational part inside the inverter. Please do not open the crust of the inverter by yourself, or it may cause electric shock. The inverter damage caused by illegal operation is out of the guarantee range.

---

**DANGER**

The damaged device or device fault may cause electric shock or firing!

- Before operating, please inspect the device and see if there is any damage or exist other danger.
  - Check if the external devices or circuit connection is safe.
- 

**DANGER**

Before checking or maintenance, if the DC side and AC side is power down just now, it is necessary to wait for 20 minutes to ensure the inner device is completely discharged, and then the operation can be performed.

---

**HIGH TEMPERATURE**

The surface temperature of the inverter may reach to 75°C. During running, please don't touch the surface to avoid scald.

---

**CAUTION**

No liquid or other objects are allowed to enter the inverter.

---

**CAUTION**

In case of fire, please use dry power fire extinguisher. If using liquid fire extinguisher, it may cause electric shock.

---

### 1.1.2 Protection for PV Array

When install the PV array in the daytime, use light-proof material to cover the PV array, or, under the sunshine, the PV array will generate high voltage. Once touch the PV array by accident, it may cause electric shock or endanger human life.

**DANGER**

There is deadly high voltage between the positive and negative of the PV array.

During installing, ensure that the connection between inverter and PV array is completely disconnected and set warning marks at the disconnection to avoid reconnecting by accident.

When the photovoltaic array is exposed to light, it supplies a DC voltage to the PCE.

---

### 1.1.3 Anti-Static Protection

**CAUTION**

The static electricity generated by human bodies may damage the electrostatic-sensitive components on boards. Before touching the sensitive component, please wear anti-static rings and well connect the other end of the anti-static rings to ground.

---

### 1.1.4 Grounding Requirements

**WARNING**

High leakage risk! The inverter must be grounded before electrical connection. The ground terminal must be connected to earth.

---

- When installing, connect the grounding wire first; when dismantling, the grounding wire must be removed at last.
- It is prohibited to damage the grounding conductor.
- The device must be connected with protection earthing permanently. Before operating, please check the electric connection and ensure the device has been connected to earth reliably.

### 1.1.5 Moisture-proof Protection



#### **CAUTION**

Moisture incursion may cause the inverter damage!

---

For normal use of the energy-storage converter, please comply with the following items.

- If the atmosphere humidity larger than 95%, please do not open the inverter.
- On overcast or rainy or moist condition, avoid opening the inverter to maintain or do other operation.

### 1.1.6 Safety Warning Label Setting

To avoid irrelevant person close to or misoperate the inverter, during installation or daily maintenance, please abide by the related standards.

- Set warning labels at the front end and back end of the inverter to avoid wrongly close and even cause accident.
- Set warning label board or safety warning area to avoid irrelevant person entering and cause human injury or device damage.

### 1.1.7 Electrical Connection

The electrical connection must be done on the basis of the illustration and electrical wiring principle mentioned in this manual.

**WARNING**

The PV array and grid level, frequency, etc must accord with the inverter's specification.

The grid-connected generation must be allowed by local power supply department and operate by professionals.

All the electrical connection must accord with the electrical installation standard of local nation and district.

---

### 1.1.8 Measure with Electricity

**CAUTION**

There is dangerous high voltage, contacting by accident may lead to deadly danger. So, when measure with electricity, it is necessary to do the protection (such as wear insulated gloves, etc.)

---

The measure meter must accord with the following requirements.

- The range and sue condition of the measure meter should conform to the site requirements.
- Ensure that connection of the measure meter is proper and normative, which is to avoid the danger of electric arc, etc.

### 1.2 Requirements for Operator

**CAUTION**

The related operation and wiring for the inverter should be performed by qualified professionals, and ensure the electric installation accord with the electricity installation standards.

---

The installation and maintenance man should be trained and know each safety announcements and get the right operation method, and then, the installation, operation and maintenance can be done.

- The operator should be familiar with the constitution and work principle of the whole PV grid-connected generation system.
- The operator must be acquainted with the related standards of local nation and region.

## 1.3 Environment Requirements



### CAUTION

Avoid the inverter suffering directly sunshine, rain or snow to prolong the service life (detail please see 3.2.2 ). If the installation environment does not meet the requirement, the service life may be influenced.

Please avoid using the inverter in the following environment for long time.

- The place where beyond the specification (normal work temperature:-25℃～60℃, relative humidity: 0%-95%).
- The place where has vibration or easy impacted.
- The place where has dust, corrosive material.
- The place where without good ventilation or closed.
- The place where is close to resident living quarters.

## 1.4 Device Label Illustration











### WARNING

The labels on the device contain important information about safety operation. Don't tear them up or damage them!

Pay attention to labels on the device. The label illustration is as shown in Table1-1.

Table1-1 The illustration of device label

Label	Illustration
CE	Pass CE authentication.
 Type Approved Safety Regular Production Surveillance www.tuv.com ID 2000000000	Pass TUV authentication.

Label	Illustration
	Don't dispose with general garbage. Recycle them by special method.
	Read user manual when using device.
	Wait for 5 minutes to discharge completely after powering device off.
	Hot surface. Don't touch!
	High leakage current, earth connection essential before connecting supply.
	Multi-channel power supplies power for energy storage inverter. Be careful of electric shock.
	External grounding label.
	Serial number barcode. The meaning(e.g. S/N: 500012000065D7400054) is as shown in Figure1-1.

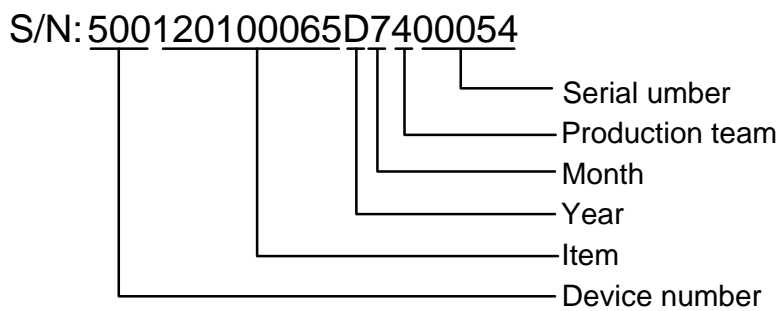

Figure1-1 The meaning of serial number barcode

## 2 Overview

This chapter mainly introduces the inverter features, appearance, operation panel, work principle, etc.

### 2.1 Product Intro

The inverter is the device that converts DC energy from solar array into AC energy and then feeds back to power grid. It is suitable for home and commercial roof PV generation system and distributed PV generation system. Generally, the system consists of PV arrays, PV grid-connected inverter and grid, as shown in Figure2-1.

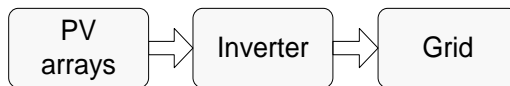

Figure2-1 Constitution of PV generation system

#### 2.1.1 Model Meaning

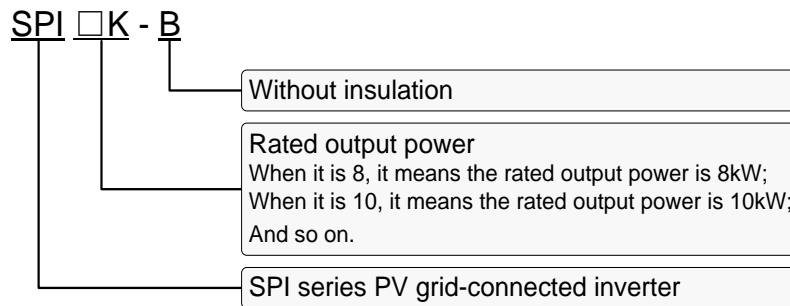

Figure2-2 Model meaning illustration

#### 2.1.2 Product Features

- Efficiently power generation: adopt high-efficiency type-T three-level high-frequency conversion technology and advanced completely digitized control technology, wide work range of MPPT and high power generation efficiency.
- Safe and reliable: adopt aluminium alloy to diecast the outer case, so that the inverter can work in a widely temperature range. The degree of protection is IP65 and it adopts whole industrial grade electron device.



- Smart manage: adopt smart cloud platform monitor and APP real-time monitor. The inverter supports RS485, GPRS and WIFI communication and it also can connect with DRM and smart meter to achieve anti- countercurrent. Besides, it can be updated and set the parameters remotely.
- Green and friendly: small size, easy installation and use.
- Better adaptability: with better grid adaptability, wide reactive power adjusting range.

## 2.2 Appearance and Structure

The appearance of the inverter is as shown in Figure2-3.

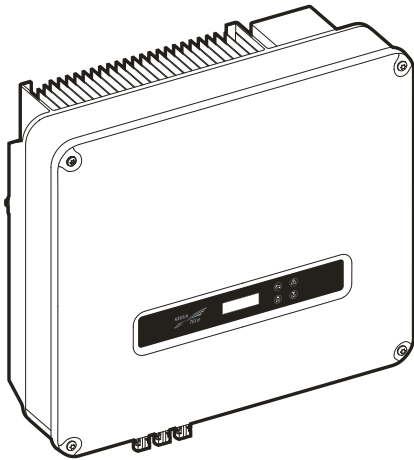

Figure2-3 Appearance

### NOTE

There is a slight difference between SPI5K-B, SPI6K-B, SPI8K-B, SPI10K-B, SPI12K-B and SPI12K-BL, SPI15K-B, SPI17K-B, SPI20K-B in the heat dissipation part and PV port, please in kind prevail.

### 2.2.1 Operation Panel

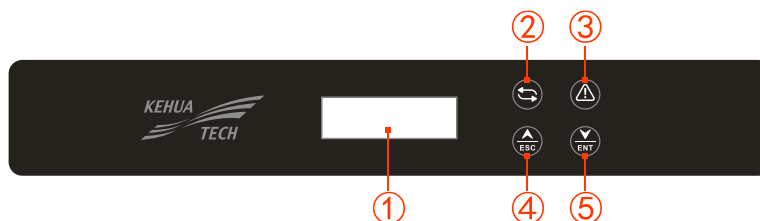





Figure2-4 Operation panel

Table2-1 Illustration of the operation panel

NO	Mark	Illustration	Remarks
①	-	LCD	<ul style="list-style-type: none"> <li>● Shows the inverter status and information.</li> <li>● Shows the service and operation information</li> <li>● Shows the alarm information and fault.</li> </ul>
②		Power indicator (green)	On: inverter is in grid-connected status. Flicker: PV power supply is normal
③		Alarm indicator (red)	On: inverter fault. Off: there is no fault.
④		ESC button	Short press: move the cursor upward or increase the setting value. Long press: back to previous menu or cancel the current command.
⑤		ENT button	Short press: move the cursor downward or decrease the setting value. Long press: enter sub menu or confirm the current command.

**NOTE**

Short press: less than 1s; Long press: more than 1s.

## 2.2.2 External Terminal Illustration

The external terminals are all located in the bottom of the inverter, including PV input, AC output, communication port and DC switch, etc, as shown in Figure2-5.

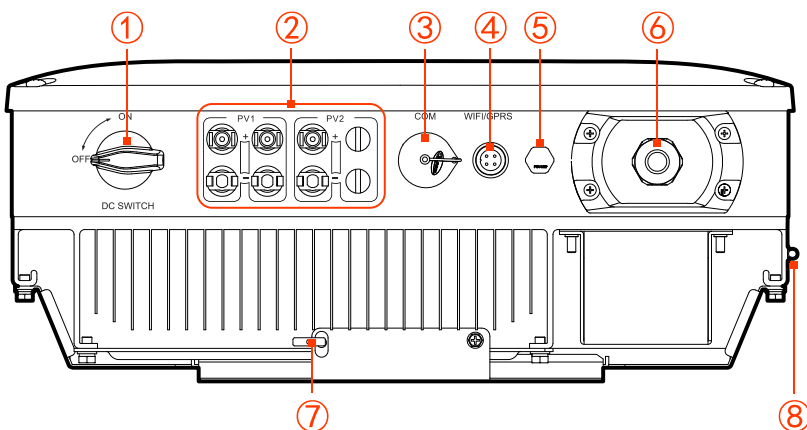

Figure2-5 Bottom view

Table2-2 Terminals illustration

NO.	Mark	Illustration	Remarks			
①	DC SWITCH	DC switch	Optional			
②	PV	<table border="1" style="display: inline-table; vertical-align: middle;"> <tr> <td style="text-align: center;">+</td> <td rowspan="2" style="vertical-align: middle;">PV input ports</td> </tr> <tr> <td style="text-align: center;">-</td> </tr> </table>	+	PV input ports	-	
+	PV input ports					
-						
③	COM.	Can be set to DRM, anti-countercurrent port	Optional.			
④	WIFI/GPRS	WIFI/GPRS port	Optional. It is used to monitor the running status of the inverter.			
⑤	-	Water-proof ventilation valve	Adjust inner air pressure.			
⑥	AC OUTPUT	AC output terminal	It is used to connect with grid.			
⑦	-	Anti-theft lock	It needs to provide by customer.			
⑧		External grounding terminal				

**NOTE**

When the DC SWITCH and communication function is not selected, the corresponding port is filled with a waterproof plug.

**DC switch**

DC switch (as shown in Figure2-5 ①) is the connection switch of inverter and PV array.

- When the inverter works normally, the DC switch must be ON.
- During installation and wiring, the DC switch must be OFF.
- Before maintenance, the DC switch must be OFF for 20 minutes, and measure the voltage of inner DC busbar by multimeter, only when the voltage less than 10V, the maintenance can be done.



### CAUTION

When maintenance or wiring, the DC switch must be disconnected.

## 2.3 Work Principle

The inverter connects with PV array input and tracks the maximum power point of the PV array, and then converts the DC power into three-phase AC power by inverter circuit. It also provides surge protection at DC and AC side, as shown in Figure 2-6.

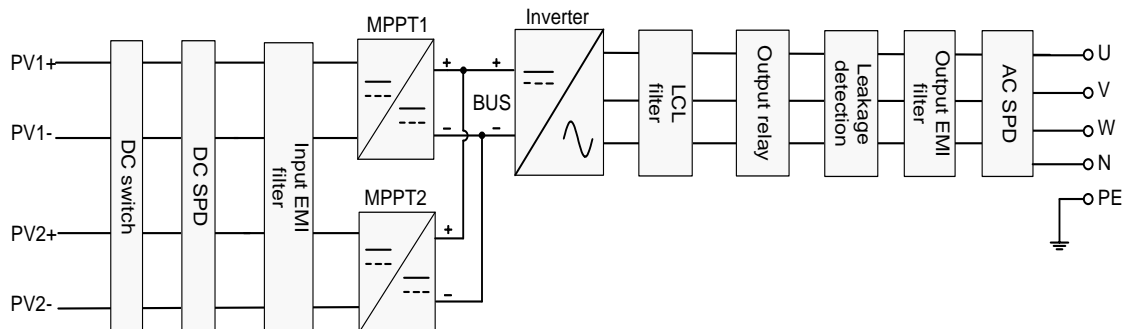

Figure 2-6 Work principle diagram



### NOTE

The DC input (PV) of SPI12K-B is 2 routes, the larger power one should be prior to connect with PV1, the other should be connected with PV2.

## 2.4 Grid Form

There are 4 supported grid type of inverter: TN-S, TN-C, TN-C-S and TT, as shown in Figure 2-7.

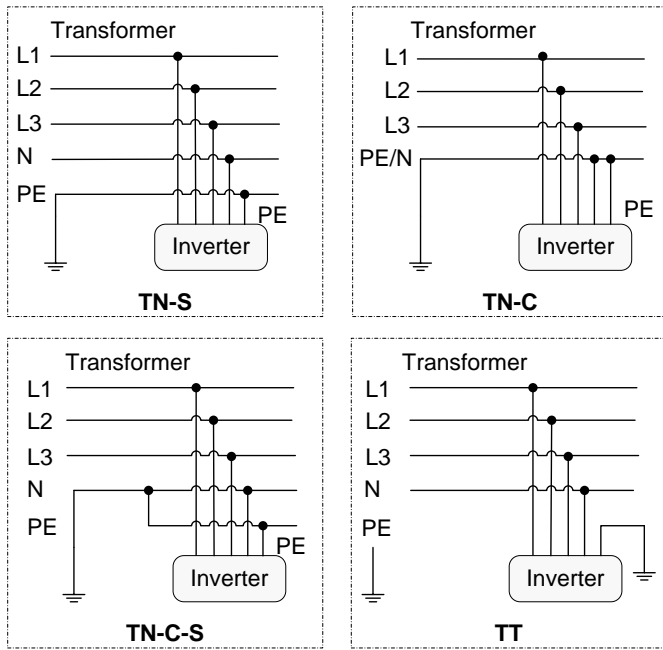

Figure2-7 Supported grid form



**CAUTION**

For type TT grid, the effective value of neutral and grounding voltage must be less than 20V.

## 3 Installation Guide

This chapter introduces the installation of the inverter, including installation process, installation preparation, transportation and unpacking, installation procedure, electrical connection and checking, etc.

### 3.1 Installation Process

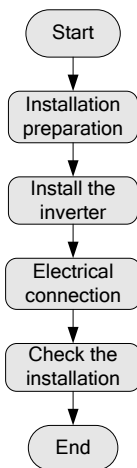
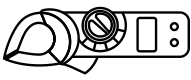
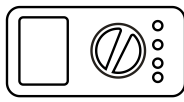

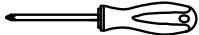



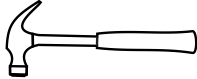
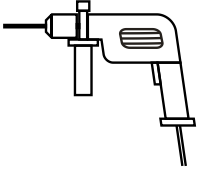
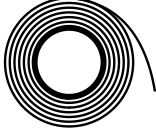
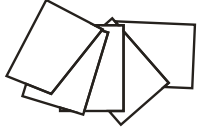
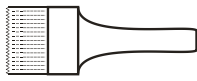
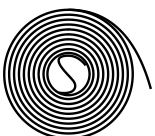
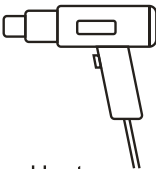
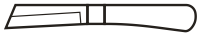
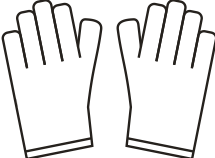
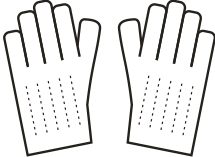
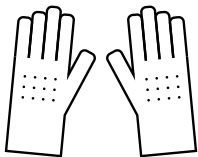



Figure3-1 Installation process

### 3.2 Installation Preparation

#### 3.2.1 Tools

Tools			
			
Clamp meter	Multi-meter	Label paper	Phillips screwdriver

Tools			
 COAX crimping tool	 Diagonal pliers	 Wire stripper	 Claw hammer
 Hammer drill	 Insulation tape	 Cotton cloth	 Brush
 Heat shrink tubing	 Heat gun	 Electrician's knife	 Protective gloves
 ESD gloves	 Insulated gloves	 Hydraulic pliers	 Cable tie

**CAUTION**

The installation tools must be insulated to avoid electric shock.

### 3.2.2 Installation Environment

- Do not install the inverter in the place with poor ventilation.
- Ensure that there has sufficient fresh-air supply around the inverter.
- The inverter must be installed on the wall or supporter with enough bearing capacity.

 **NOTE**

- The inverter is rated at IP65 for outdoor and indoor installation. But if the inverter is installed under directly sunshine, its temperature will rise quickly, so, do not install the inverter under directly sunshine.
- It is suggested to install the inverter under shade as shown in Figure3-2 to maximize the inverter lifespan and efficiency.
- For easy viewing and operating the inverter please consider the visibility of the indicators and LCD during installation.



Figure3-2 Recommended installation site

### 3.2.3 Installation Space

Keep at least 250mm from the left and right side of the inverter to other objects or inverters, keep at least 350mm from the top of the inverter to ceiling and keep at least 600mm from bottom of the inverter to ground, which is good for heat dissipation or maintenance, as shown in Figure3-3.

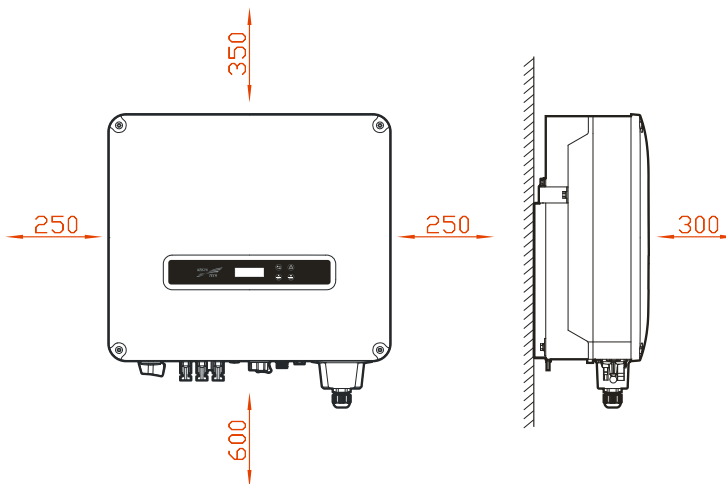

Figure3-3 Installation space (unit: mm)



### 3.2.4 Installation Way

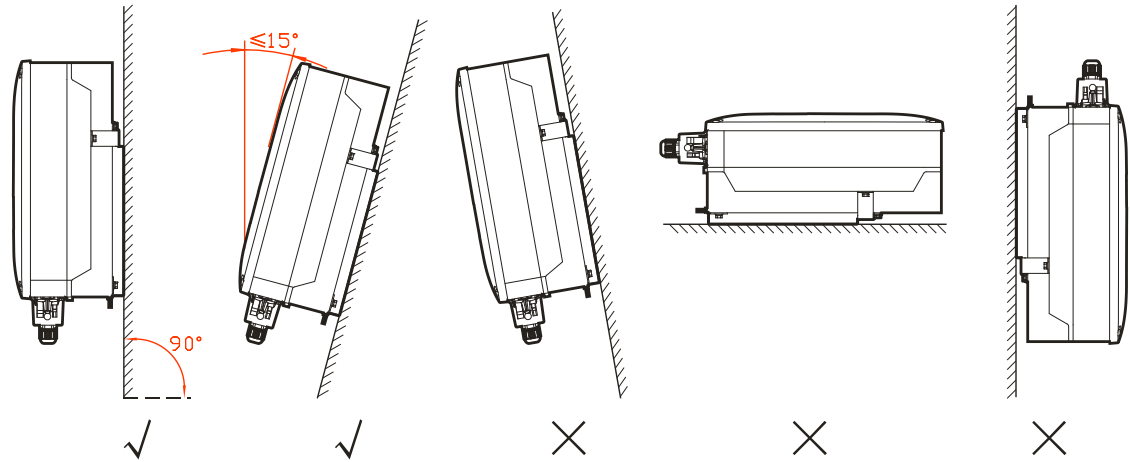

Figure3-4 Installation way

## 3.3 Transportation and Unpacking

### 3.3.1 Transportation

The inverter should be transported by trained professional (at least 2 persons).



#### CAUTION

During transporting, please take care and avoid impacting or dropping.

During transporting, keep the inverter vertically, do not put it down or put it up suddenly.

### 3.3.2 Unpacking and Checking



#### NOTE

Select the unpacking site in advance. In principle, the unpacking site should be as close to the installation site as possible.

The inverter has been tested and checked strictly, but it still may be damaged during transporting, so, please check it carefully.

- Inspect the inverter's appearance, if any shipping damage is found, report it to the carrier and your local dealer immediately.
- Check if the types of the accessories are complete and correct. If there is any discrepancy, take notes and contact the distributor immediately.

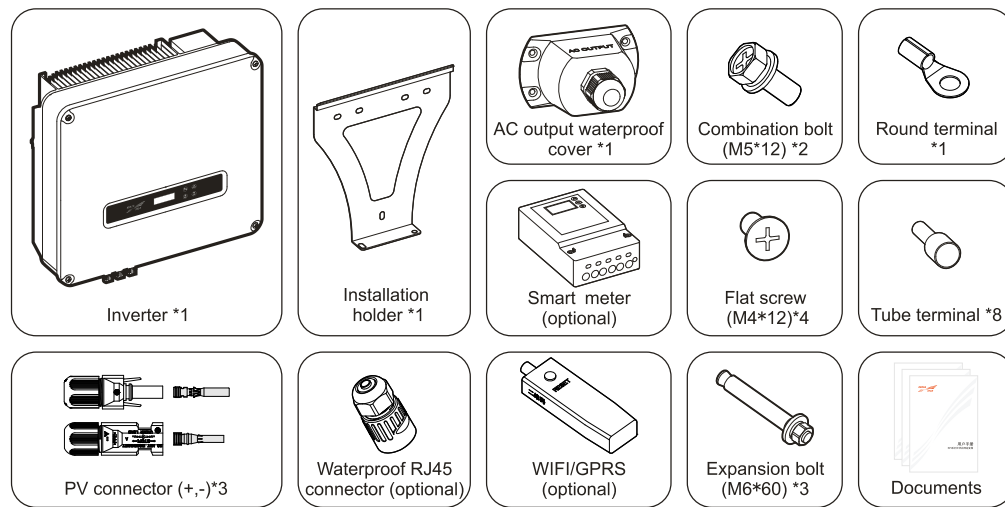

Figure3-5 Packing list

#### NOTE

1. There are three PV connector parts of SPI5K-B, SPI6K-B, SPI8K-B, SPI10K-B, SPI12K-B series inverter, and there are four PV connector parts of SPI12K-BL, SPI15K-B, SPI17K-B, SPI20K-B series inverter, the actual configuration in order to prevail in kind.
2. WiFi/GRPS, waterproof RJ45 connector and smart meter are optional, they are provided according to the contract.
3. The documents include User Manual, Installation Guide, QC passed, Packing List, User Service card, Warranty Card, Statement of Toxic and Hazardous Substances, Product Quality Inspection Report, Business License, Solar Energy Certification.

**CAUTION**

If the inverter needs to be stored for a long time after unpacking, it is necessary to pack the inverter by original package and save properly.

## 3.4 Installation

The inverter can be installed on the wall or metal holder through equipped installation holder.

**CAUTION**

Vertical installation is perfect. If it is installed aslant, the vertical gradient should not exceed  $\pm 15^\circ$ .

In this section, we take wall installation as example to illustrate, if the inverter needs to be installed on metal installation holder, please adjust the installation step correspondingly.

- Step 1 Determine the installation place based on the inverter size (as shown in Figure3-6) and installation space (as shown in **3.2.3 Installation Space**).

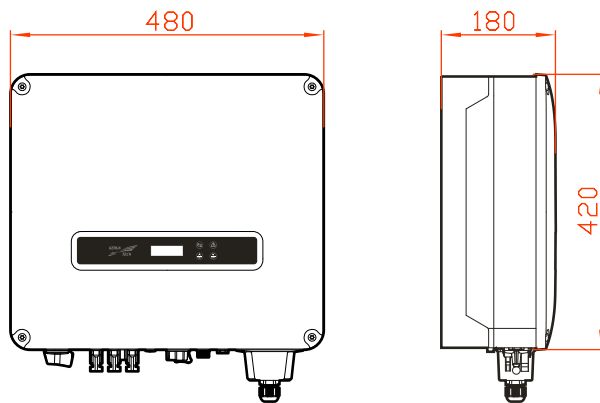

Figure3-6 Size (unit: mm)

- Step 2 Mark the position of installation holes on the wall according to the dimensions of the fixing holes of the installation holder (as shown in Figure3-7), and drill 3 holes of  $\Phi 10.5\text{mm}$  on the wall according to marked position, as shown in Figure3-8.

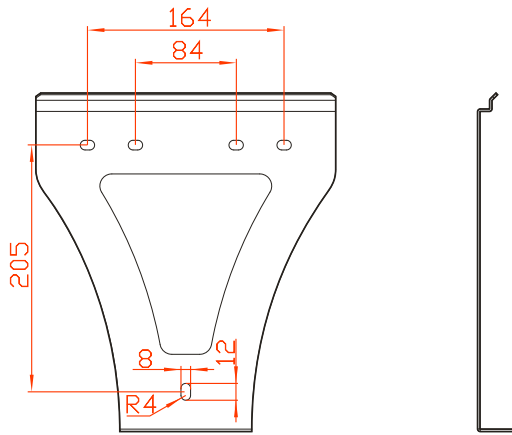

Figure3-7 Installation size (unit: mm)

**CAUTION**

When installation, please keep the installation holder horizontal and the installation holes aligned.

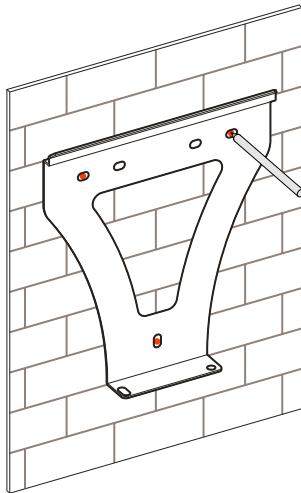

Figure3-8 Mark the drilling position

**NOTE**

The depth of drilled holes should be within 40mm. Clear the dust and measure the net depth. Ensure that the depth of three holes is the same.

Step 3 Install the equipped 3 expansion bolts M6\*60 into the holes, as shown in Figure3-9.

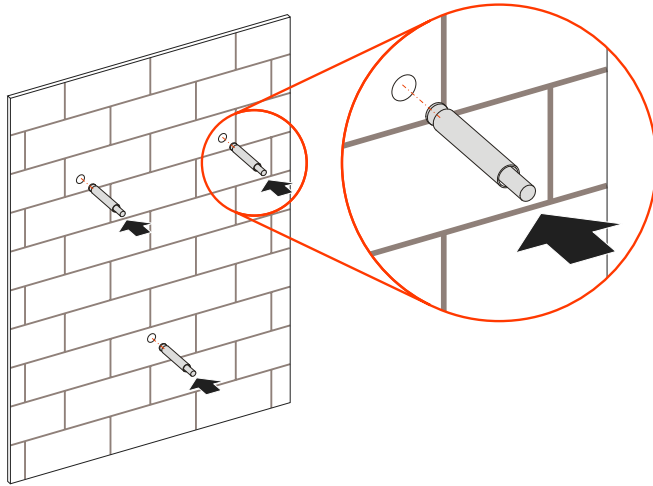

Figure3-9 Install expansion bolts

- Step 4 Align the holes of installation holder with the expansion bolts and install the flat gasket, spring gasket and nut into the expansion plugs and fasten them by wrench, as shown in Figure3-10.

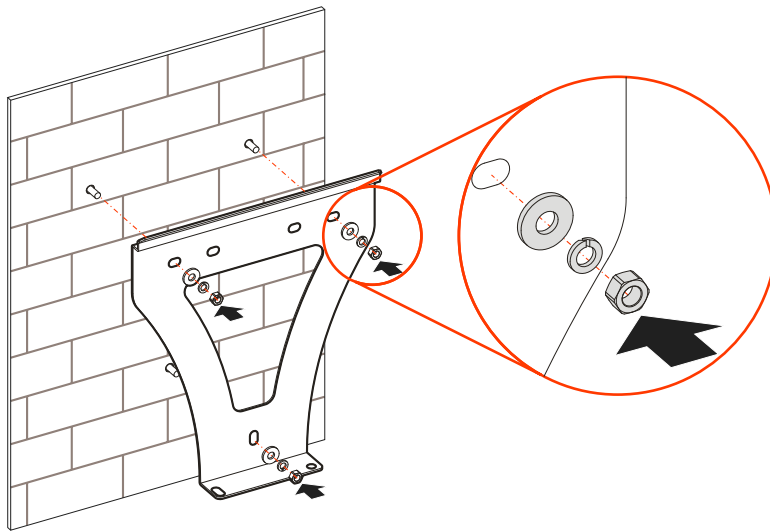

Figure3-10 Fasten the installation holder

- Step 5 Uplift the inverter and hang the inverter to the installation holder, as shown in Figure3-11.

**CAUTION**

Do not loosen the inverter until the inverter has been hung in the installation holder completely.

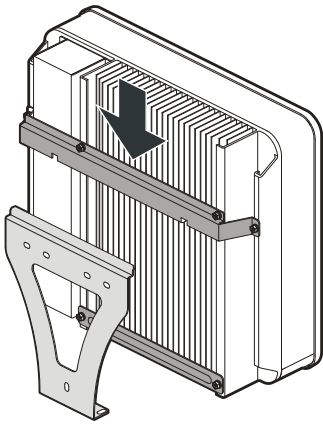

Figure3-11 Hang the inverter to installation holder

- Step 6 Fasten the inverter to the installation holder by stainless steel combination bolt M5\*12 (as shown in Figure3-12) and then lock it. The lock position is as shown in Figure3-13.

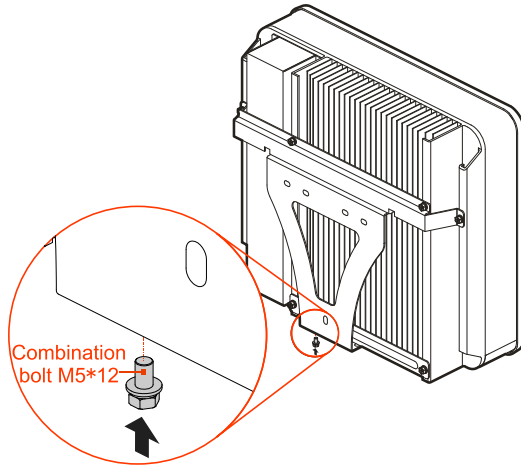

Figure3-12 Fasten the inverter

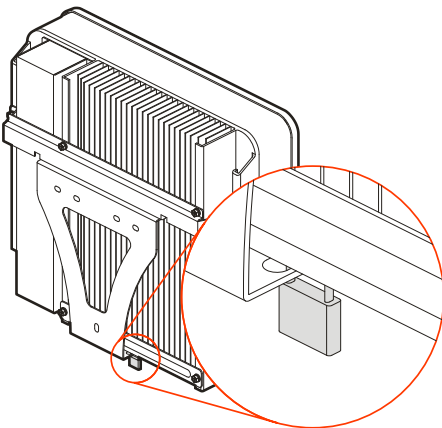

Figure3-13 Position of lock (The lock customer provided)

---End

### 3.5 Electrical Connection

#### 3.5.1 Wire Requirement

The wiring of the inverter all at the bottom, as shown in Figure2-5 and Table2-2. The corresponding recommended wire specification as shown in Table3-1.

Table3-1 Wire specification

Type	Specification
DC input (PV)	4 mm <sup>2</sup> and above
AC output (AC OUTPUT)	5*4mm <sup>2</sup> and above multi-core cable (SPI5K-B, SPI6K-B, SPI8K-B, SPI10K-B) 5*6mm <sup>2</sup> and above multi-core cable (SPI12K-B, SPI15K-B, SPI17K-B, SPI20K-B)
COM. communication wire	8-core network wire
Grounding wire	4 mm <sup>2</sup> ~6 mm <sup>2</sup>

#### 3.5.2 External Grounding Connection



#### WARNING

The external grounding wire cannot replace the PE wire of AC output terminal, they all must be connected with ground reliably.

- Step 1 Strip the insulation layer of grounding wire for about 7mm, insert the wire into round terminal and crimp them by crimping tool, as shown in Figure3-14.

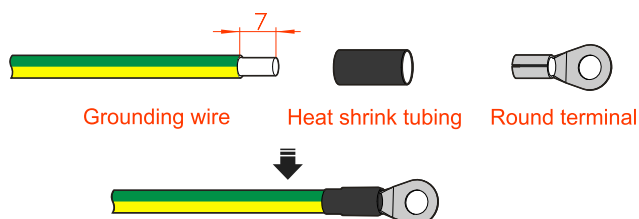

Figure3-14 Stripping diagram of external grounding wire (unit: mm)

Step 2 Connect the crimped grounding wire to the external grounding terminal by stainless steel combination bolt M5\*12, as shown in Figure3-15.

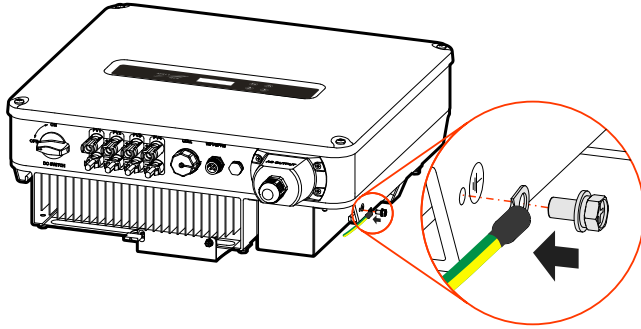

Figure3-15 External grounding wire connection



### CAUTION

The grounding of inverter and the lightning rod of the installed building cannot be the same, they must be separated, as shown in Figure3-16. The grounding wire of the inverter must connect to the grounding system directly, and the impedance must be less than 20mΩ.

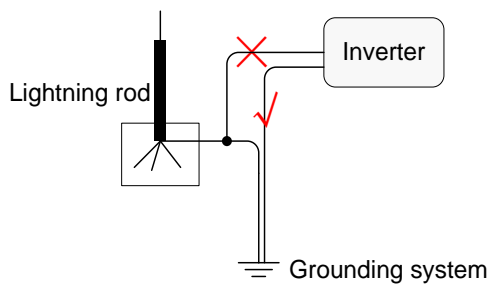

Figure3-16 Inverter grounding diagram

----End

### 3.5.3 DC Input (PV) Connection



**CAUTION**

- When installation, use the equipped DC terminals to avoid inverter damage.
- Polycrystalline silicon, monocrystalline silicon and thin-film without grounding.
- Switch off the DC switch before connecting the PV array.
- It is recommended to use independent breaker for each PV input, and before connecting, the breakers must be off. We suggest to use the special DC breaker (rated voltage is 1000V, rated current is more than 20A).
- Ensure that the connection between PV array and the inverter at positive pole and negative pole is correctly.
- The DC input voltage should be less than the max. input voltage of the inverter.
- It's forbidden to connect the positive pole or negative pole of PV array with grounding, or it will lead to inverter damage.
- The not connected PV port must be disposed with waterproof and shockproof.

**NOTE**

The inverter has two routes of MPPT. The model, quantity, installation angle and direction of the two routes PV arrays that connected with PV1 or PV2 must be the same. If the system just has two routes PV array, do not connect them to PV1 at the same time. The larger power one should be prior to connect with PV1, the other should be connected with PV2.

Use the equipped PV connector and metal terminal to connect the PV input. The PV connector includes positive connector and negative connector, they match the corresponding positive metal terminal and negative terminal, corresponding procedure as follows.

Step 1 Strip the insulation layer of positive wire and negative wire for about 7mm, as shown in Figure3-17.



Figure3-17 Stripping diagram of DC input (unit: mm)

 **NOTE**

It is recommended to use red wire as the positive wire, use black wire as negative wire to avoid wrong connection. If using the wires of other colour, please confirm the corresponding connection relationship.

- Step 2 Unscrew the lock nut of positive and negative PV connector, lead the positive and negative wires go through corresponding lock nut and then insert the positive wire and negative wire into the positive metal terminal and negative metal terminal respectively. Crimp the metal terminals firmly by crimping pliers, as shown in Figure3-18.

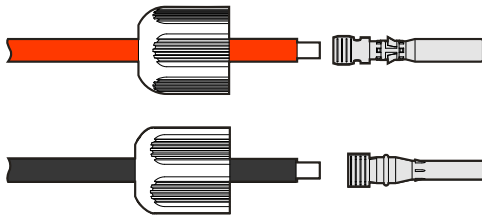

Figure3-18 Crimp the metal terminal

- Step 3 Insert the crimped positive wire and negative wire into corresponding insulation crust respectively. If there has a click sound, it means that the wire have been inserted properly, as shown in Figure3-19.

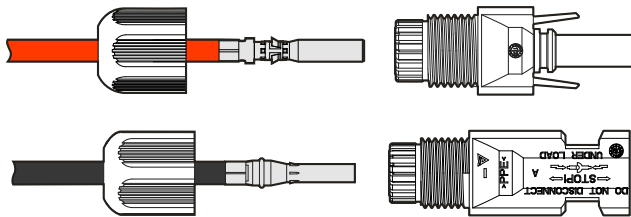

Figure3-19 Fasten the metal terminal

- Step 4 Tighten the sealing nuts of positive connector and negative connector to the corresponding insulation crusts respectively, as shown in Figure3-20.

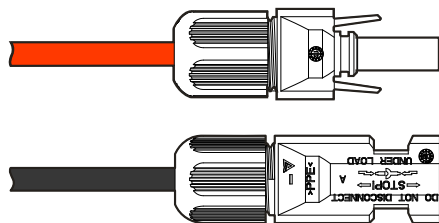

Figure3-20 Tighten the sealing nuts

- Step 5 Measure the voltage and check if the positive and negative is connected properly and if the voltage within the input range of the inverter.

**CAUTION**

The two routes PV input that connected with PV1 or PV2 have been parallel connected at the inner of the inverter. DO NOT reverse connect the PV array, or it will cause the system or inverter damage permanently.

- Step 6 Insert the positive connector and negative connector to the PV + and PV – terminals (as shown in Figure3-21) and tighten them. If there has a click sound, it means that the connector have been inserted properly.

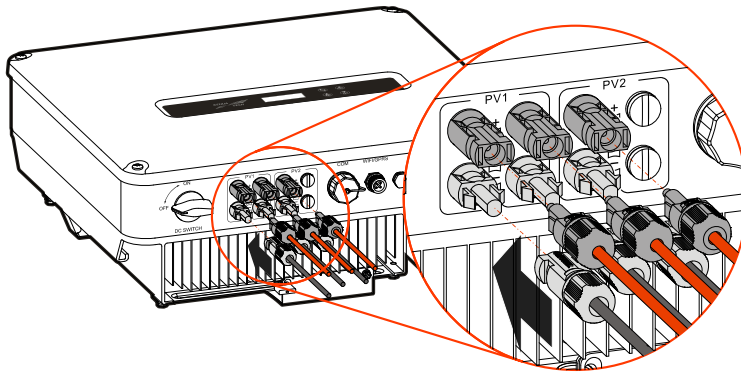

Figure3-21 Connect the PV connector

**NOTE**

If there are only two routes PV arrays, the PV input of SPI12K-B should be connected to PV1 and PV2, and the larger power one should be prior to connect with PV1, the other should be connected with PV2. The installation way is the same. In above figure, we take SPI10K-B, SPI8K-B as an example to illustrate.

**CAUTION**

The not connected PV port must be disposed with waterproof and shockproof, and the corresponding plug must be fastened properly.

----End

### 3.5.4 AC Output (AC OUTPUT) Connection



#### CAUTION

It's forbidden that several inverters share an AC breaker.

It's forbidden to connect with load between inverter and the AC breaker.

To ensure the inverter can be disconnected with load safely, we suggest equipping independent tripolar or quadropole breaker for each inverter to protect the inverter. Before connecting with grid, ensure that the grid parameters are all in the allowable range of the inverter.

Table3-2 Recommended AC breaker specification

Model	Specification
SPI5K-B	20A
SPI6K-B	20A
SPI8K-B	25A
SPI10K-B	32A
SPI12K-B	32A
SPI12K-BL	32A
SPI15K-B	63A
SPI17K-B	63A
SPI20K-B	63A



#### CAUTION

During wiring, please pay attention to distinguish the AC live wire, neutral wire and grounding wire.

- Step 1 Strip the external insulation layer of AC cable for about 70mm, strip the inner lead insulation layer for about 15mm, as shown in Figure3-22.

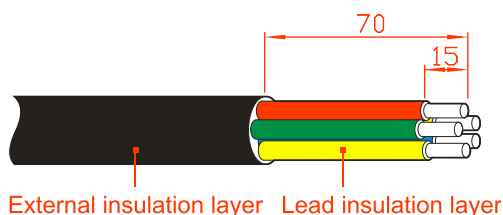

Figure3-22 Stripping diagram of AC output (unit: mm)

**NOTE**

If the cable is hard, comparing with wire U and PE, strip the wire V, W and N less than 5mm so that the wire U and PE can be easily screw to the wiring terminal (the wire colour of yellow, green, red, blue and yellow-green stand for wire U, V, W, N and PE respectively. If using the wires of other colour, please confirm the corresponding connection relationship.)

Step 2 Lead the AC output cable go through the AC output waterproof cover, crimp them to the tube terminals, and then fasten them to corresponding wiring terminal by screwdriver, as shown in Figure3-23.

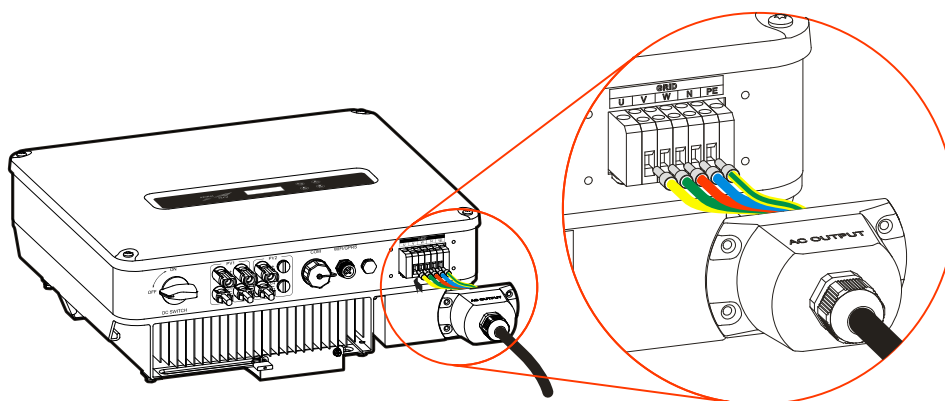

Figure3-23 Connect the AC output cable

Step 3 After wiring, fasten the AC output waterproof cover to the inverter (as shown in Figure3-24) by four flat screw M4\*12 and then screw the external AC output nut.

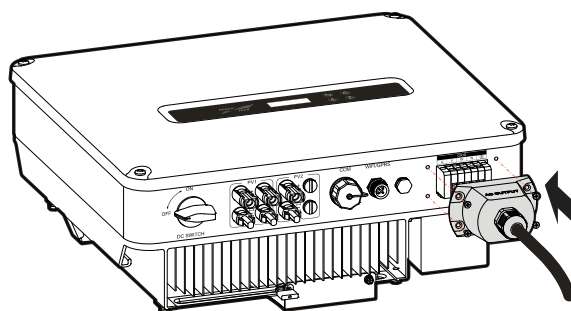

Figure3-24 Fasten the AC output waterproof cover



**CAUTION**

When several inverters are parallel connected, it needs to equip the breaker with impact tripping function at the rear end of the AC output of the inverter.

----End

### 3.5.5 WIFI/GPRS Communication Connection

If the inverter is equipped with WIFI/GPRS, insert it to the WIFI/GPRS port (as shown in Figure3-25) to monitor on the internet. The monitor way is as shown in Figure3-26.

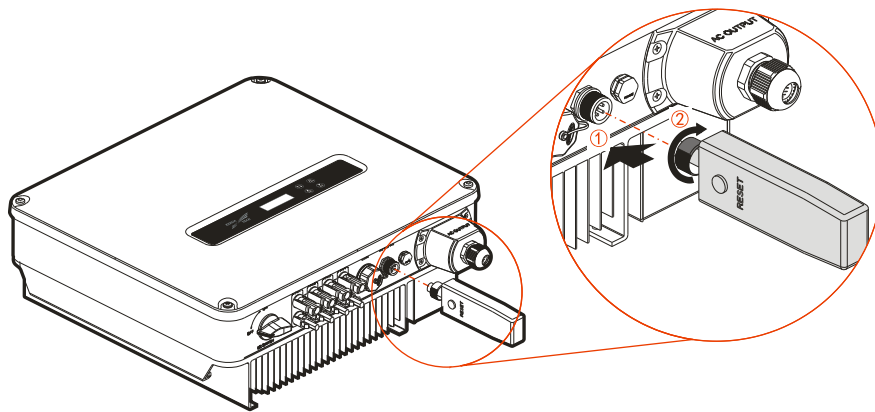

Figure3-25 WIFI/GPRS communication connection

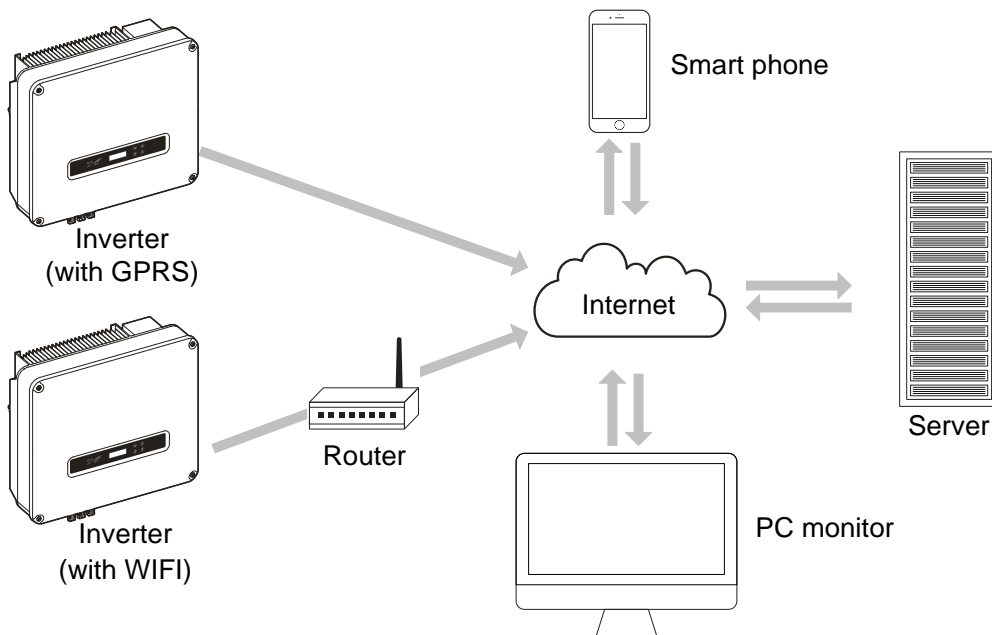

Figure3-26 WIFI/GPRS monitor way

**NOTE**

The GPRS do not need to set.

User can scan the two-dimension code below to obtain the user manual and APP of WIFI and GPRS to use.



Domestic APP



Foreign APP



User Manual (Chinese)



User Manual (English)

### 3.5.6 COM. Communication Connection(Options)

COM. port can set to DRM and RS485 communication port, they all adopt RJ45 plug to connect. The pin definition of RJ45 plug is as shown in Figure3-27.

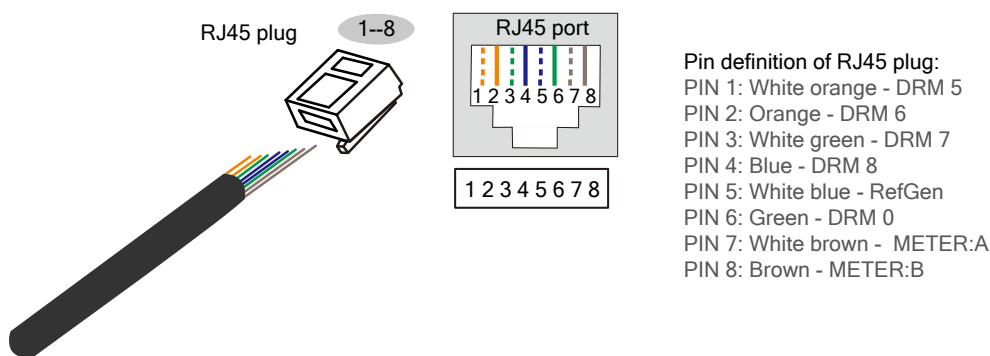

Figure3-27 Pin definition of inverter’s RJ45 plug

#### DRM port

DRM is used to connect the DRM controlling device.



**CAUTION**

When the COM. port set to DRM port, the PIN7 and PIN8 of inverter’s RJ45 plug cannot connect wires. The PIN7 and PIN8 of external DRM adapter’s RJ45 plug must be short connected together.

## RS485 communication port

RS485 communication port is used to communicate with smart meter to achieve anti-countercurrent. The connection between smart meter and inverter and grid is as shown in Figure3-28.

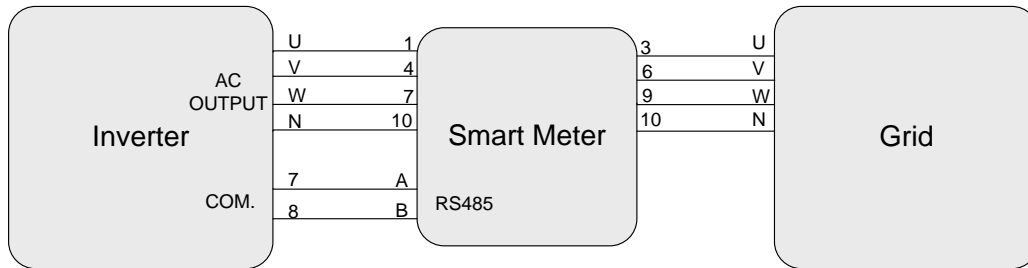

Figure3-28 Connection diagram between communication smart meter and inverter and grid

### NOTE

When using the anti-countercurrent function, the following setting must be done:

1. Set the anti-countercurrent enable in “System Setting-General Setting-I/O switch” to open;
2. Set the anti-countercurrent power in “System Setting-General Setting-Engineer set” according to the actual use (the setting value of anti-countercurrent power is percentage, it is corrected by rated power. For example, when the rated power of the inverter is 10kW, if the anti-countercurrent power set to 30%, the set Smart feed-in control power is 3kW).

The pin illustration of smart meter is as shown in Table3-3, detail installation please the instruction manual.

Table3-3 Pin illustration of smart meter

Pin	Illustration
1	Connect to AC OUTPUT phase-U of the inverter.
3	Connect to grid phase-U.
4	Connect to AC OUTPUT phase-V of the inverter.
6	Connect to grid phase-V.
7	Connect to AC OUTPUT phase-W of the inverter.
9	Connect to grid phase-W.
10	Connect to AC OUTPUT phase-N of the inverter and phase-N of grid.
RS485: A	Connect to pin7 of the waterproof RJ45 connector.
RS485: B	Connect to pin8 of the waterproof RJ45 connector.



## Connection procedure

The connection of COM. port is as follows.

- Step 1 Strip the insulation layer of communication wire, unscrew the lock nut of waterproof RJ45 connector (as shown in Figure3-29) and then lead the communication wire go through the RJ45 connector and crimp it to the RJ45 plug.

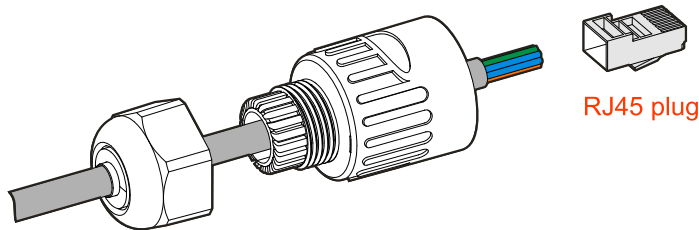

Figure3-29 Crimp the wires of RJ45 plug

- Step 2 After crimping, insert the RJ45 plug into the buckle (as shown in Figure3-30), and then, screw the RJ45 port.

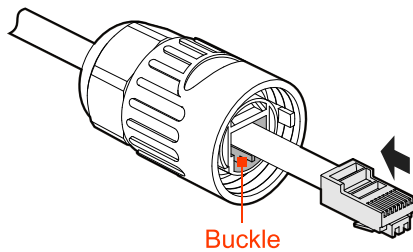

Figure3-30 Buckle position

- Step 3 Unscrew the waterproof cover on the COM. port, insert the RJ45 connector to the COM. port (as shown in Figure3-31) and screw it.

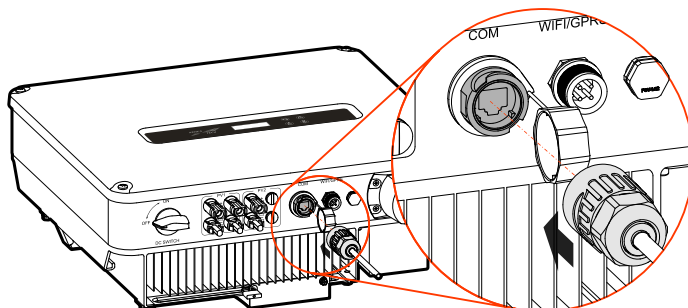

Figure3-31 Insert the COM. port

----End

## 3.6 Check the Installation

After installation, check the following items:

- Check if the connection of DC input, AC output and communication wire are right.
- Check if the inverter is installed firmly.
- Check if all the screws of wiring are tightened.

# 4 LCD Operation

This chapter introduces the operation of LCD.

## 4.1 Display Interface

The system display adopts the hierarchical menu structure, as shown in Figure4-2, and operates through the function keys on the operation panel, as shown in Table4-1.

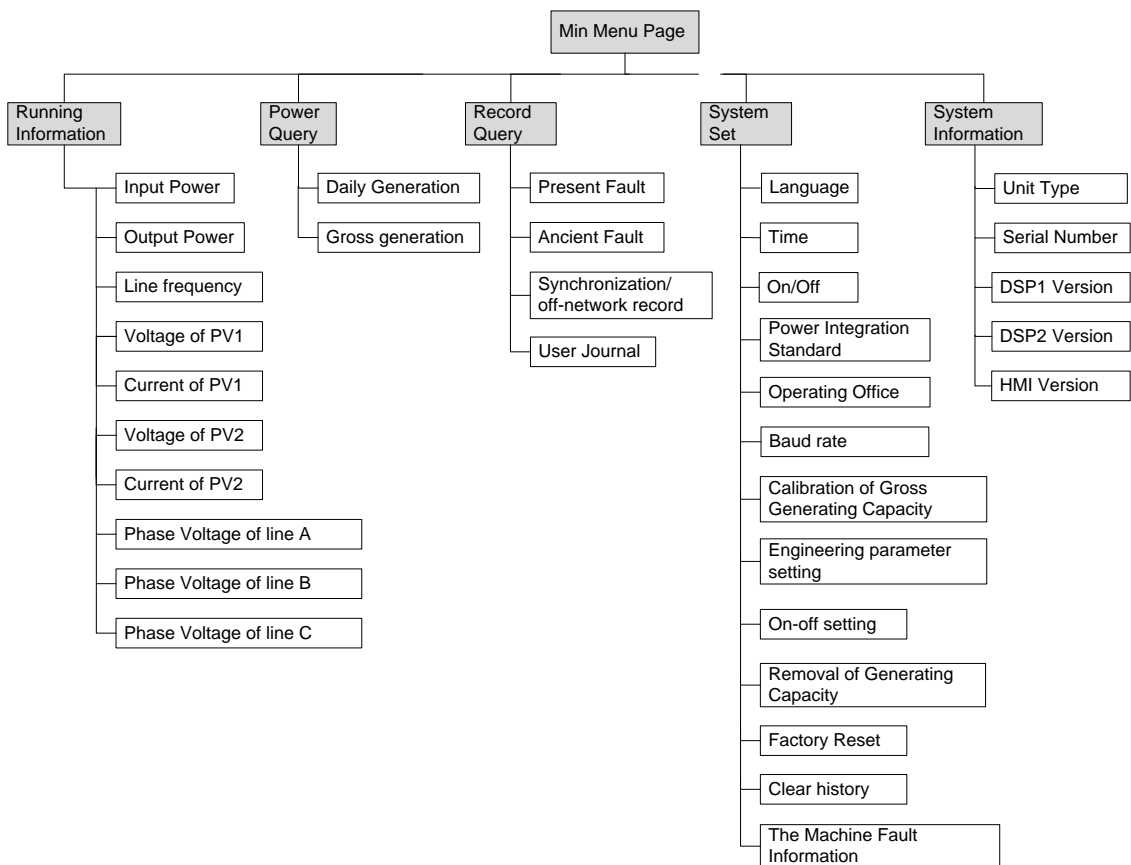



Figure4-1 Display interface frame system

Table4-1 Button function on power-on password page

Button	Function
	<ul style="list-style-type: none"> <li>● Short press: add the number value</li> <li>● Long press: clear enter value, the cursor back to the first position</li> </ul>
	<ul style="list-style-type: none"> <li>● Short press: reduce the number value</li> <li>● Long press: confirm the current entering, and the cursor move to right</li> </ul>

## 4.2 First Startup

When first power on, if it shows the power-on password page, as shown in Figure4-2, please contact the agent to obtain the startup password. The corresponding button function is as shown in Table4-1. After entering the right password, it will show the main page.

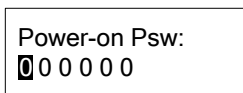

Figure4-2 Power-on password page

## 4.3 Main Page

Main page can show date & time, inverter status, as shown in Figure4-3. When the inverter is grid-connected, the main page will show the daily power, gross power and output power circularly.

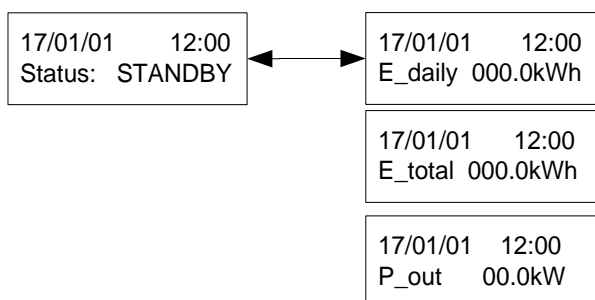

Figure4-3 Main page

There are 5 sub-menu, including running information, power query, record query, system setting and system information, as shown in Figure4-4

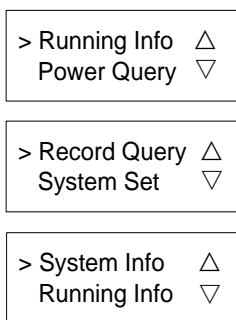

Figure4-4 Function selection page

### 4.3.1 Running Information

In main menu page, select **Running Info**, the LCD will show the running information, as shown in Figure 4-5.

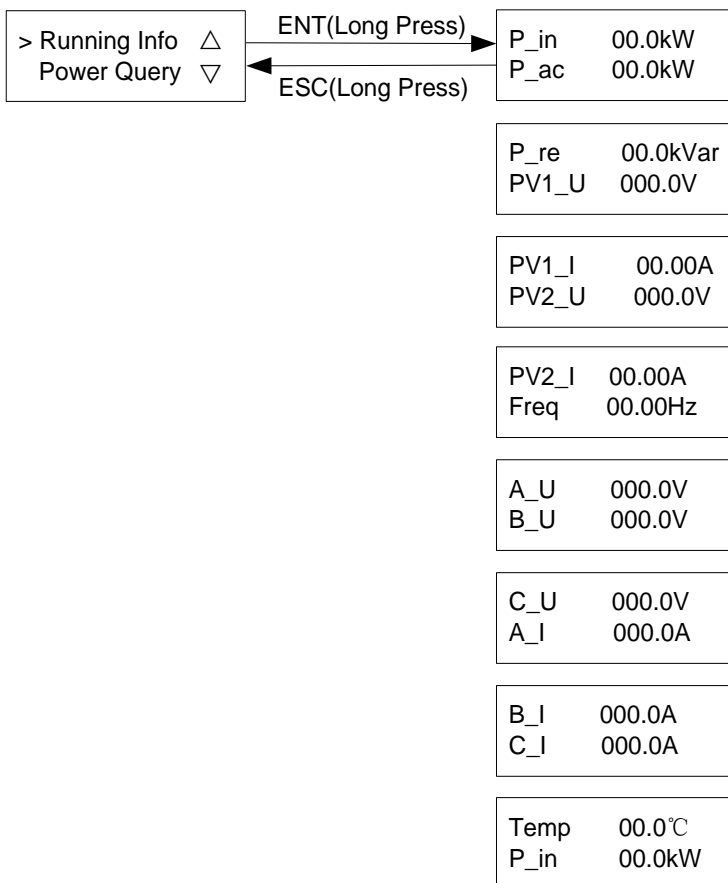

Figure4-5 Running information page

### 4.3.2 Power Query

In main menu page, select **Power Query**, the LCD will show the power query page. In this page, it shows the daily power and total power, as shown in Figure 4-6.

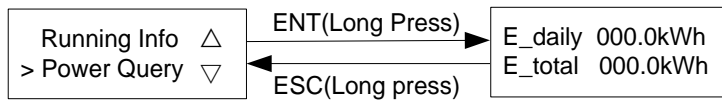

Figure4-6 Power query page

### 4.3.3 Record Query

In main menu page, select **Record Query**, the LCD will show the record query page. In this page, it shows the current fault, history fault, user log, grid-connected and off-grid record, as shown in Figure4-7.

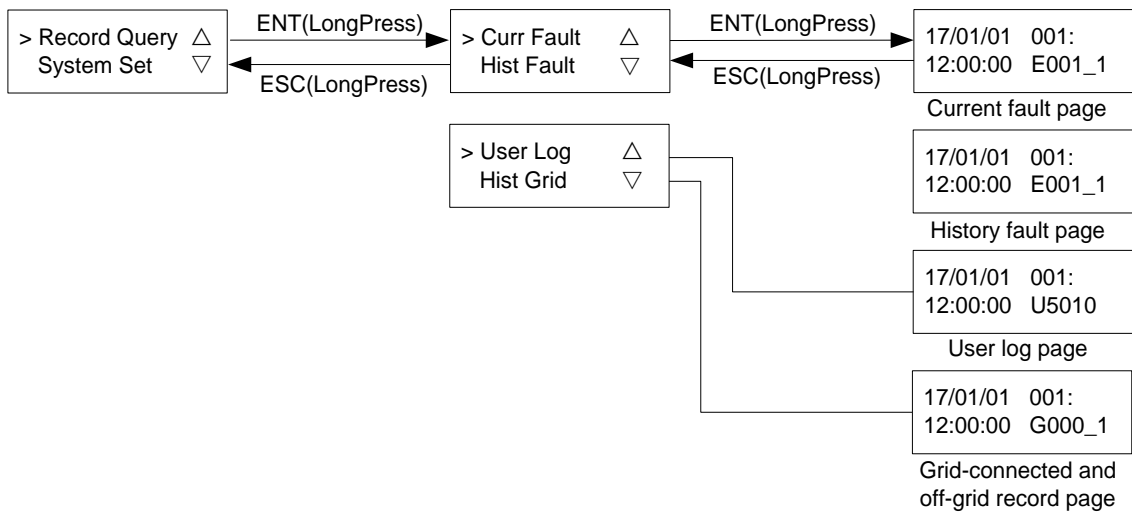

Figure4-7 Record query page

**NOTE**

Detailed fault info and dispose method please see Table6-1.

Table4-2 Corresponding list of user log code and information

User log code	User log information
U5000	ON/OFF setting
U5003	Initiative islanding enable setting
U5004	Power mode setting
U5005	Anti-PID function setting
U5007	Self-start after power on setting

User log code	User log information
U5008	Clear arc fault
U6000	Active power control setting
U6003	Reactive power control setting
U6200	Grid-connected recover time setting

Table4-3 Corresponding list of grid-connected and off-grid record code and information

Record code	Record information
G000	Grid-connected
G001	Off-grid

#### 4.3.4 System Setting

In main menu page, select **System Setting**, it will enter user login page. Select user and enter password, it will enter the page of corresponding user authority.

User includes general user (User) and administrator (Admin), as shown in Figure4-8.(Initial password of the User is 000111, and the Admin is 000111, the user password of operation and maintenance is the manufacturer permission password. If user need this password,. please contact with our company.)

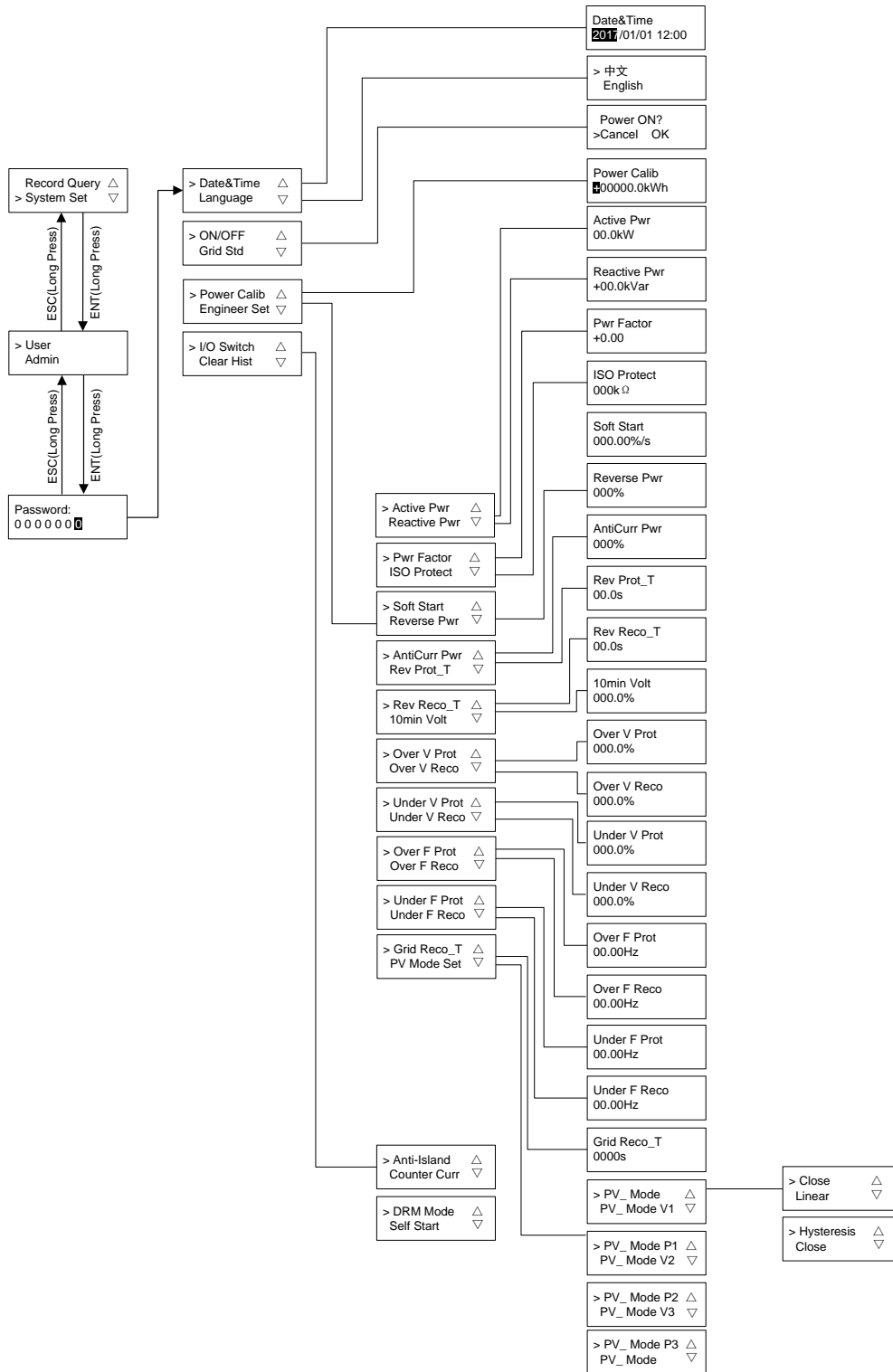

Figure4-8 Select user authority page



**NOTE**

The grid standards includes China, America, California, Germany, Australia, New Zealand, England, Thai PEA, Thai MEA, Italy, France, Canada, France VFR, France SEI, France CRAE, France VDE, Netherlands, Spain, EN50438, Country Grid, Urban Grid, user etc.

The setting values of 10min Volt, Over V Prot, Rev Reco\_T, Under V Prot, Under V Reco are all ratios. The effective values can be obtained by the product of rated voltage and setting ratio. For example, when 10min Volt is set to 111.3%, the effective value of 10min Volt is 255.99V(230V\*111.3%=255.99V).

### 4.3.5 System Information

In main menu page, select **System Info**, the LCD will show the system information, as shown in Figure4-9.

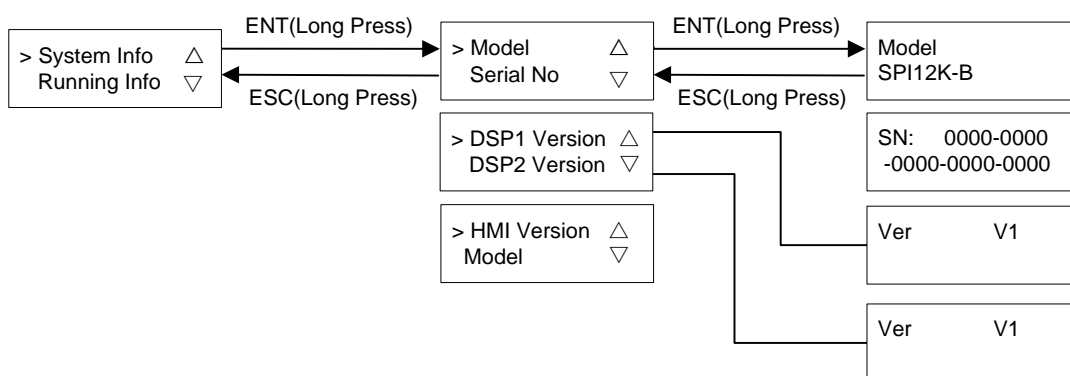



Figure4-9 System information

## 5 Startup and Shutdown

This chapter introduces how to start and shut down the inverter.

### 5.1 Startup

- Step 1 Switch on the DC switch (optional) and DC switch in the project site. When the PV arrays provide enough startup voltage, the LCD will enter the main interface.
- Step 2 Switch on the AC switch between inverter and grid. If the " " alarm indicator on the operation panel doesn't light on, the LCD will show "current status: standby".
- Step 3 When the DC and AC supply power normally, the inverter will prepare to start. At first, the inverter will check the inner parameters and AC grid parameters, if they are in the normal range, 60s later, the inverter will check the insulation impedance.
- Step 4 About 60s, the inverter will generate power normally. The " " power indicator on the operation panel will be on and the LCD will show: "current status: grid-connected".

----End

### 5.2 Shutdown

- Step 1 Switch off the DC switches of the inverter and site, after a while, the " " power indicator on the operation panel light off.
- Step 2 Disconnect the connection of the inverter and grid.

----End

## 6 Maintenance and Troubleshooting

This chapter mainly introduces the maintenance and troubleshooting for the inverter.

### 6.1 Maintenance

#### 6.1.1 Inverter Maintenance



#### **WARNING**

The maintenance must be done after the inverter power is down.

---

The inverter does not need to be maintained regularly, but dust or debris may influence the heat dissipation performance, so use a soft brush to clean the inverter. If the surface of the LCD and LED indicator is too dirty to read, use a wet cloth to clean them.



#### **HIGH TEMPERATURE**

During running, do not touch the inverter. The temperature of some parts on the inverter is too high, and may cause scald injury. After shutting down the inverter and waiting until it has cooled down, then do the maintenance and clean.

---



#### **CAUTION**

Do not clean the inverter with any solvent, abrasive material or corrosive material.

---

#### 6.1.2 Fan Maintenance (SPI12K-BL, SPI15K-B, SPI17K-B, SPI20K-B)

The inverter has two fans to cool during operation. If the fan does not work properly, then the inverter does not cool effectively, that the inverter's efficiency may be affected.

Therefore, it is necessary to keep the fan clean and replace the damaged fan in time. The cleaning and replacement steps of the fan are as follows:

- Step 1 Disconnect the AC breaker.
- Step 2 Rotate the DC switch to the "OFF" position and disconnect all DC input.
- Step 3 Wait at least 10 minutes.
- Step 4 Disconnect all electrical connections.
- Step 5 Dismantle the cover plate.

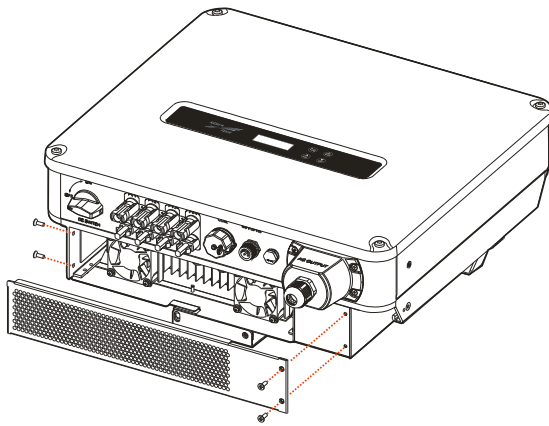

Figure6-1 Dismantle the cover plate

- Step 6 Disconnect the connector connected with fan.

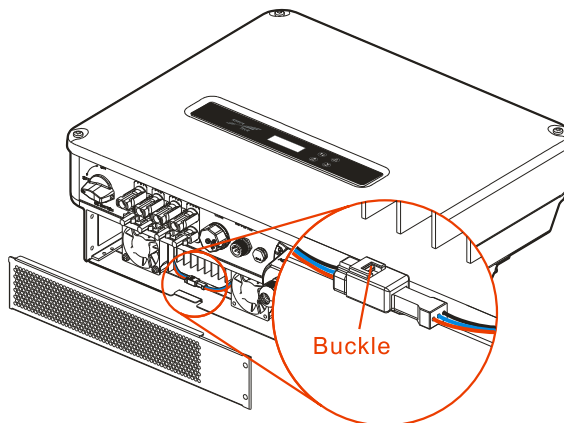

Figure6-2 Disconnect the connector

- Step 7 Loosen the screws that fixed the fan and take out fans.

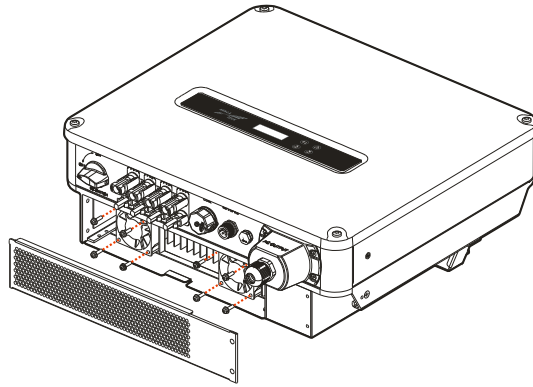

Figure6-3 Dismantle fan

Step 8 Clean the fan with a soft brush or vacuum cleaner; Or replace the damaged fan (wind direction: up).

Step 9 After maintenance, install the fan in reverse order.

Step 10 Restart the inverter.

----End

## 6.2 Troubleshooting

The inverter is designed on the basis of the grid-connected operation standards and meets the requirements of safety and EMC. Before provided to client, the inverter has been experienced for several rigorous tests to ensure reliable and optimizing operation.

If some faults occur, the display screen will show the corresponding alarm information. Under the circumstances, the inverter may stop power generation. The troubleshooting is as shown in Table6-1.

Table6-1 Troubleshooting

Code	Fault information	Solution
E016	Grid voltage abnormal	<ul style="list-style-type: none"> <li>● Check if the safety provision of the inverter meets the local grid-connected requirement.</li> <li>● Check the local grid voltage.</li> <li>● If they are all normal, please contact local distributor.</li> </ul>
E017	Grid frequency abnormal	<ul style="list-style-type: none"> <li>● Check if the safety provision of the inverter meets the local grid-connected requirement.</li> <li>● Check the local grid voltage.</li> </ul>

Code	Fault information	Solution
		<ul style="list-style-type: none"> <li>● If they are all normal, please contact local distributor.</li> </ul>
E019	Output over-current	If the fault always exists, please contact the local distributor.
E022	Output current DC component abnormal	If the fault always exists, please contact the local distributor.
E024	Leakage current abnormal	<ul style="list-style-type: none"> <li>● Check the insulation resistance of positive and negative of PV array to ground.</li> <li>● Check the environment and see if the environment is too moist.</li> <li>● Check the grounding connection and see if the connection is loose.</li> <li>● If they are all normal, please contact local distributor.</li> </ul>
E025	Relay fault	If the fault always exists, please contact the local distributor.
E028	Radiator over-temperature	<ul style="list-style-type: none"> <li>● Check the radiator, and see if it is blocked</li> <li>● Check the environment temperature and see if the temperature exceeds the normal range.</li> <li>● If they are all normal, please contact local distributor.</li> </ul>
E032	Insulation fault	<ul style="list-style-type: none"> <li>● Check the insulation resistance of positive and negative of PV array to ground.</li> <li>● Check the environment and see if the environment is too moist.</li> <li>● Check the inner grounding and see if the connection is loose.</li> <li>● If they are all normal, please contact local distributor.</li> </ul>
E039	Fan fault	If the fault always exists, please contact the local distributor.
E042	Inverter inner over-temperature	<ul style="list-style-type: none"> <li>● Check the radiator, and see if it is blocked.</li> <li>● Check the environment temperature and see if the temperature exceeds the normal range.</li> <li>● If they are all normal, please contact local distributor.</li> </ul>
E064	MPPT1 over-voltage	Check the configuration of PV array. If they are all normal, please

Code	Fault information	Solution
		contact local distributor.
E065	MPPT2 over-voltage	Check the configuration of PV array. If they are all normal, please contact local distributor.
E072	MPPT1 over-current	If the fault always exists, please contact the local distributor.
E073	MPPT2 over-current	If the fault always exists, please contact the local distributor.

**CAUTION**

If the inverter has any alarm information mentioned in Table6-1, please shut down the inverter(refer to **5.2 Shutdown**), 5 minutes later, restart the inverter (refer to**5.1 Startup**). If the alarm status is not removed, please contact our local dealer or service centre. Before contacting us, please prepare the following information.

1. Inverter S/N.
2. Distributor/ dealer of the inverter(if has).
3. The date of grid-connected power generation.
4. Problem description (that is the alarm information displayed on the display screen and the status of indicators and other information obtained from information menu (refer to **4.3.3 Record Query**)).
5. Your detail contact information.

# 7 Package, Transportation and Storage

This chapter introduces the package, transportation and storage of the inverter.

## 7.1 Package

The inverter is packaged by carton. When packaging, pay attention to the placing direction requirements. On the side of the carton, there has warning icons, including keep dry, handle with care, up, stacking layer limit, etc. On the other side of the carton, it prints the device model, etc. On the front side of the carton, there is the logo of Kehua company and device name.

## 7.2 Transportation

During transporting, pay attention to the warnings on the carton. DO NOT make the device impact severely. To avoid damaging the device, place the inverter strictly according to the placement direction. DO NOT carry the inverter with the objects that is inflammable, explosive, or corrosive. DO NOT put the inverter in the open-air while midway transshipment. Leaching or mechanical damage by rain, snow or liquid objects is prohibited.

## 7.3 Storage

During storage, place the inverter strictly according to the direction that showed on the carton. Keep at least 20cm from the bottom of the carton to floor and keep at least 50cm from the carton to wall, heat source, cold source, windows or air inlet.

The storage environment temperature is  $-40^{\circ}\text{C}\sim 70^{\circ}\text{C}$ . After storing or transporting the inverter beyond the work temperature, keep the inverter aside and make its temperature return to normal range for more than 4h before installation. In warehouse, the poisonous gas, inflammable or explosive or corrosive chemical objects are prohibited. Besides, strong mechanical shaking, impact or strong magnetic field is also prohibited. Under the storage conditions above, the storage period is six months. If the inverter is stored beyond six months, it should be rechecked.



# A Technical Specifications

## A.1 Technical Specifications

Item	Model	SPI5K-B	SPI6K-B	SPI8K-B	SPI10K-B	SPI12K-B
	DC input					
Max. input power (kW)		6.8	8.1	10.8	13.5	16.2
Max. input voltage (V)		1000				
MPPT voltage range (V)		200-950				
Full-load MPPT voltage range (V)		240-850	280-850	300-850	350-850	300-850
Startup voltage (V)		200/250				
No. of MPPTs		2				
Strings per MPPT		1/1	1/1	2/1	2/1	2/1
Max. input current (A)		22 (11/11)	22 (11/11)	33 (22/11)	33 (22/11)	22 (11/11)
Isc PV (d.c.A)		13.8/13.8	13.8/13.8	27.5/13.8	27.5/13.8	13.8/13.8
Maximum inverter backfeed current to array(A)		0				
Overvoltage category		OVCII				
AC output						
Rated output power (kW)		5	6	8	10	12

Item	Model				
	SPI5K-B	SPI6K-B	SPI8K-B	SPI10K-B	SPI12K-B
Max. output power (kW/kVA) for AS/NZS 4777.2:2015	5	6	8	10	12
Max. output power (kW/kVA)	5.5	6.6	8.8	11	13.2
Rated grid voltage (Vac)	400				
Grid voltage range (V)	320-480				
Grid type	3W+N+PE				
Rated output current (A)	7.3	8.7	11.6	14.5	17.4
Max. output current (A)	8.0	9.6	12.8	16.0	19.1
Rated grid frequency (Hz)	50/60				
Grid frequency range (Hz)	45-55/55-65				
Maximum output fault current a.c. (A)	43.5@130us				
Maximum output overcurrent protection a.c. (A)	29.9				
Current (inrush) peak and duration (A)	8.2@10ms				
Power factor (rated power)	>0.99				
Power factor adjusting range	0.8 ahead ~0.8 lag(0.8* rated power)				
Output harmonic content rated condition)	<3%(test on rated power) <5%(load is 50% rated power)				
DC component	<0.5%I <sub>n</sub>				
Overtoltage category	OVCIII				

Item	Model	SPI5K-B	SPI6K-B	SPI8K-B	SPI10K-B	SPI12K-B
	Efficiency					
Max. efficiency	98.5%					
Europe efficiency	98.0%					
Protection						
DC reverse connection protection	Yes					
Anti-island protection	<2s					
AC short-circuit protection	Yes					
Leakage current protection	Yes					
DC switch	Optional					
Input DC impedance monitor	Yes					
Surge protection	Yes Class D, Piezoresistor					
Standard & certification	IEC62109-1/-2, EN62109-1/-2, AS4777.2-2015, (G83/2 G59/3) VDE4105 EN50438 AS 62040 CGC/CQC CE					
Size (W×H×D) (mm)	480*420*180					
Weight (kg)	23 (Max.)					
Installation	Wall-mounting					
Insulation	No transformer					
Degree of protection	IP65					
Self-consumption at night	<1W					
Operating temperature range	-25~60℃ (If the temperature higher than 45℃, the inverter needs to decrease rated power to use)					
Relative humidity	0~100%, without condensation					

Item	Model	SPI5K-B	SPI6K-B	SPI8K-B	SPI10K-B	SPI12K-B
	Cooling	Natural-cooling				
Maximum operating altitude	4000m (>3000m derating)					
Noise	<30db @ 1m					
Display	LCD/LED/button					
Communication	WIFI/GPRS(optional), RS485(optional), DRM (optional)					
AC terminal	Wiring terminal bars (4 mm <sup>2</sup> ~6 mm <sup>2</sup> )					
DC terminal	MC4(4 mm <sup>2</sup> ~6 mm <sup>2</sup> )					
Other function						
Whole machine	Update online					

## A.2 Technical Specifications

Item	Model	SPI12K-BL	SPI15K-B	SPI17K-B	SPI20K-B
	DC input				
Max. input power (kW)	16.2	20.3	23.0	27.0	
Max. input voltage (V)	1000				
MPPT voltage range (V)	200-950				
Full-load MPPT voltage range (V)	300-850	350-850	400-850	460-850	
Startup voltage (V)	200/250				
No. of MPPTs	2	2	2	2	
Strings per MPPT	2/2	2/2	2/2	2/2	
Max. input current (A)	44 (22/22)	44 (22/22)	44 (22/22)	44 (22/22)	

Item \ Model	Model			
	SPI12K-BL	SPI15K-B	SPI17K-B	SPI20K-B
Isc PV (d.c.A)	27.5/27.5			
Maximum inverter backfeed current to array(A)	0			
AC output				
Rated output power (kW)	12	15	17	20
Max. output power (kW/kVA) for AS/NZS 4777.2:2015	12	15	17	20
Max. output power (kW/kVA)	13.2	16.5	18.7	22
Rated grid voltage (Vac)	380/400/415			
Grid voltage range (V)	320-480			
Grid type	3W+N+PE			
Rated output current (A)	18.2/17.4/16.7	22.8/21.7/20.9	25.8/24.6/23.7	30.4/29.0/27.8
Max. output current (A)	19.1	23.9	27.1	31.9
Rated grid frequency (Hz)	50/60			
Grid frequency range (Hz)	45-55/55-65			
Maximum output fault current a.c. (A)	78.9@130us			
Maximum output overcurrent protection a.c. (A)	54.4			
Current (inrush) peak	8.2@10ms			

Item	Model	SPI12K-BL	SPI15K-B	SPI17K-B	SPI20K-B
	and duration (A)				
Power factor (rated power)	>0.99				
Power factor adjusting range	0.8 ahead ~0.8 lag(0.8* rated power)				
Output harmonic content (rated condition)	<3%(test on rated power) <5%( load is 50% rated power)				
DC component	<0.5%I <sub>n</sub>				
Efficiency					
Max. efficiency	98.50%			98.60%	
Europe efficiency	98.00%			98.30%	
Protection					
DC reverse connection protection	Yes				
Anti-island protection	<2s				
AC short-circuit protection	Yes				
Leakage current protection	Yes				
DC switch	Optional				
Input DC impedance monitor	Yes				
Surge protection	Yes Class D, Piezoresistor				
Standard & certification	IEC62109-1/-2, EN62109-1/-2, AS4777.2-2015, (G83/2 G59/3) VDE4105 EN50438 AS 62040 CGC/CQC CE				

Item	Model	SPI12K-BL	SPI15K-B	SPI17K-B	SPI20K-B
	Size (W×H×D) (mm)	480*420*180			
Weight (kg)	25 (Max.)				
Installation	Wall-mounting				
Insulation	No transformer				
Degree of protection	IP65				
Self-consumption at night	<1W				
Operating temperature range	-25~60℃ (If the temperature higher than 45℃, the inverter needs to decrease rated power to use)				
Relative humidity	0~100%, without condensation				
Cooling	Smart force air cooling				
Maximum operating altitude	4000m (>3000m derating)				
Noise	<50db @ 1m				
Display	LCD/LED/button				
Communication	WIFI/GPRS(optional), RS485(optional), DRM (optional)				
AC terminal	Wiring terminal bars (4 mm <sup>2</sup> ~6 mm <sup>2</sup> )				
DC terminal	MC4(4 mm <sup>2</sup> ~6 mm <sup>2</sup> )				
Other function					
Whole machine	Update online				

- Specifications are subject to change without prior notice.

# B Acronyms and Abbreviations

## A

**AC** Alternating Current

## D

**DC** Direct Current

## L

**LCD** Liquid Crystal Display

**LED** Light-emitting Diode

## M

**MPPT** Maximum Power Point Tracking

## P

**PE** Protective Earthing

**PV** Photovoltaic

## R



**RS485**                      Recommend Standard485

**U**

**USB**                      Universal Serial Bus



**KEHUA HENGSHENG CO., LTD.**

4402-02661 002

---

ADD: No. 457, Malong Road, Torch High-Tech Industrial  
Zone, Xiamen, Fujian, China(361000)  
TEL: 0592-5160516(8 lines) FAX: 0592-5162166  
Http: //www.kehua.com

Manufacturer: Zhangzhou Kehua Technology Co., Ltd.  
ADD: Beidou Industrial Zone, Jinfeng Industrial District,  
Zhangzhou, Fujian, China(363000)  
TEL: 0596-2600000 2600886 FAX: 0596-2895827